

# RENAULT TRUCKS TRAFIC



# TAKE THE ROAD WITH RENAULT TRUCKS

Driving with Renault Trucks means choosing a partner committed to supporting you, whenever you need it.

It means being able to select the most effective and technical solution. It means being able to choose trucks that are functional, efficient and comfortable.

It also means choosing easy to use, tried and tested technologies that are right for your business.

It involves building a strong, warm and lasting partnership.

It means making the right choice.



## → PIONEERS SINCE 1894

Marius Berliet designed his first engine back in 1894. Louis Renault founded the Renault Frères company in 1898. With this heritage of excellence in the production of trucks in France, Renault Trucks is carrying on a long tradition of expertise and innovation that saw the appearance of the first electric truck in 1923 and the flat platform cab in 1990. We put businesses on the road to high performance. From 2.8 tonnes to 120 tonnes, Renault Trucks is the only truck manufacturer that offers an expansive range of vehicles that can support any business need.

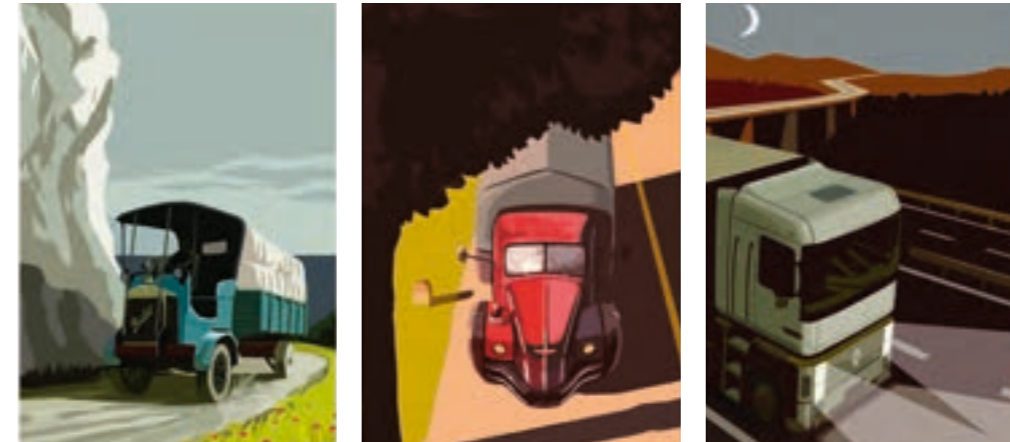

## → COMMITTED TO THE FUTURE

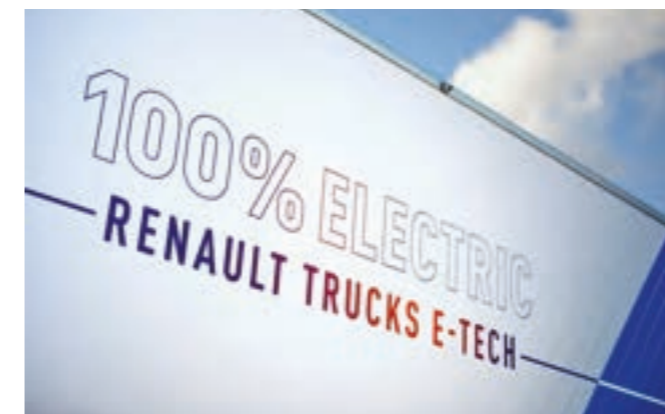

We can provide the right transport solution at the right time with the right energy solution, with minimal environmental impact. Renault Trucks provides solutions to efficiently reduce pollution and CO<sub>2</sub> emissions: optimised diesel engines and biofuels, 100% electric trucks as well as a range of services promoting strong environmental performance.

## → RESPONSIBLE MANUFACTURER

As a member to the UN Global Compact, Renault Trucks is committed to reducing its impact on our climate and to using resources and conducting business in a responsible manner. Renault Trucks has had its social responsibility audited by the independent Ecovadis organisation, which has ranked it among the best performing companies in its sector.



# THE TRAFIC RED EDITION - ONLY AT RENAULT TRUCKS

For more than 35 years, Renault Trucks has supported business by putting its heavy truck expertise at the service of professionals that drive commercial vehicles. Explore the Trafic Red EDITION, which puts the finishing touches to Renault Trucks' range of commercial vehicles.

## ACROSS THE ENTIRE TRAFIC RANGE



## KEY STANDARD FEATURES OF THE TRAFIC RED EDITION

EXTERIOR	INTERIOR
<ul style="list-style-type: none"><li>• Chrome grille</li><li>• Half-painted front bumper</li><li>• Body-coloured rail covers and light mounts</li></ul>	<ul style="list-style-type: none"><li>• Chrome effect dashboard</li><li>• Refrigerated glove compartment</li><li>• Wireless smartphone charger</li><li>• Carbon fabric upholstery</li><li>• Manual air-conditioning</li><li>• Cruise control with downhill braking + speed limiter</li><li>• Automatic activation of headlights and windscreen wipers</li></ul>



**Red**  
By RENAULT  
TRUCKS

# TRAFFIC RED EDITION - EXCLUSIVE TO RENAULT TRUCKS

Optional extras to add to the standard Traffic Red EDITION to provide a premium experience.



## KEY STANDARD FEATURES OF THE TRAFFIC RED EDITION EXCLUSIVE

### AN EXCLUSIVE EXTERIOR DESIGN

- Uniform colour across the whole vehicle body
- Exclusive diamond-cut alloy wheels
- Aluminium load sill
- Fog lamps
- 5 colours, including 4 metallic
- Unique red livery

### ENHANCED DRIVING COMFORT

- Driver's seat with lumbar adjustment and armrest
- Folding passenger seat with shelf and storage
- Non-brushed aluminium grain dashboard
- Geometric fabric upholstery
- 4.2" colour main display
- 8" screen and smartphone mirroring
- Synthetic leather steering wheel
- LED cab lighting
- Hands-free card
- Red rubber matting

### A LOADING AREA DESIGNED FOR PROFESSIONALS

DELIVERY pack:

- 270° panelled rear doors (L2H1)
- Panelled partition and hatch (van)
- LED loading lights

**Red**  
**Rd**  
By RENAULT  
TRUCKS



# PEACE OF MIND FOR YOUR BUSINESS

Renault Trucks is the perfect time-saving partner for your business: fast and efficient servicing, extended opening hours and 24/7 assistance including recovery. Optimise your vehicle's uptime by maintaining its full potential through our established truck dealer network - unique offer in this vehicle category.



# EXPERTS AT YOUR SIDE

You can rely on a whole network of Renault Trucks professionals. With almost 1400 service points across Europe, there will always be a dealer near you.

## FAST & PROFESSIONAL, SPACE DEVOTED EXCLUSIVELY TO COMMERCIAL VEHICLES:

- Expert, trained technicians
- Extended opening hours, including Saturday mornings\*
- Fast appointments for repairs and maintenance

\*May vary by dealership.



## QUALITY PARTS AND RELIABLE SERVICE FOR PEACE OF MIND AT WORK



### 3 YEARS / 100,000 MILES EXTENDED WARRANTY COVERING PARTS AND LABOUR.

3 years parts, breakdown and towing warranty for all operations carried out at an approved Renault Trucks repairer.

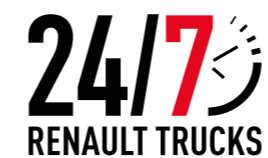

### 24/7 BREAKDOWN SERVICE

With a network of experts capable of responding to your needs in 16 languages, a coordinator will be your exclusive point of contact for any work that has to be done. Breakdowns are dealt with by specially trained roadside technicians who use special vehicles and work with dedicated diagnostic tools.



### ORIGINAL PARTS PACKAGE

Quality original parts: reliable, strong and approved to maintain vehicle performance.



### EXCHANGE PACKAGE

Reconditioned parts available to maintain your vehicle performance by giving them a second life.



# KEEP COSTS DOWN WITH OUR TAILOR-MADE PACKAGES

## MAINTENANCE PACKAGES

Our prices are fixed in advance and repairs are carried out using original parts to guarantee the performance of your work vehicles.

## MAINTENANCE CONTRACT PACKAGES

### START & DRIVE PACKAGE

REFERENCE	PERFORMANCE		EXCELLENCE
	STANDARD	MAXI	
			OPTION
	OPTION	OPTION	WEAR PARTS
OPTION	REPAIRS (complete vehicle)	REPAIRS (complete vehicle)	REPAIRS (complete vehicle)
PREVENTIVE MAINTENANCE	PREVENTIVE MAINTENANCE	PREVENTIVE MAINTENANCE	PREVENTIVE MAINTENANCE

## ALL-IN-ONE FINANCING

Renault Trucks Financial Services offers a number of financing plans (traditional credit, leasing and hire purchase), as well as tailor-made insurance products. Our all-in-one package gives you complete control over your total cost of ownership - with no nasty surprises.

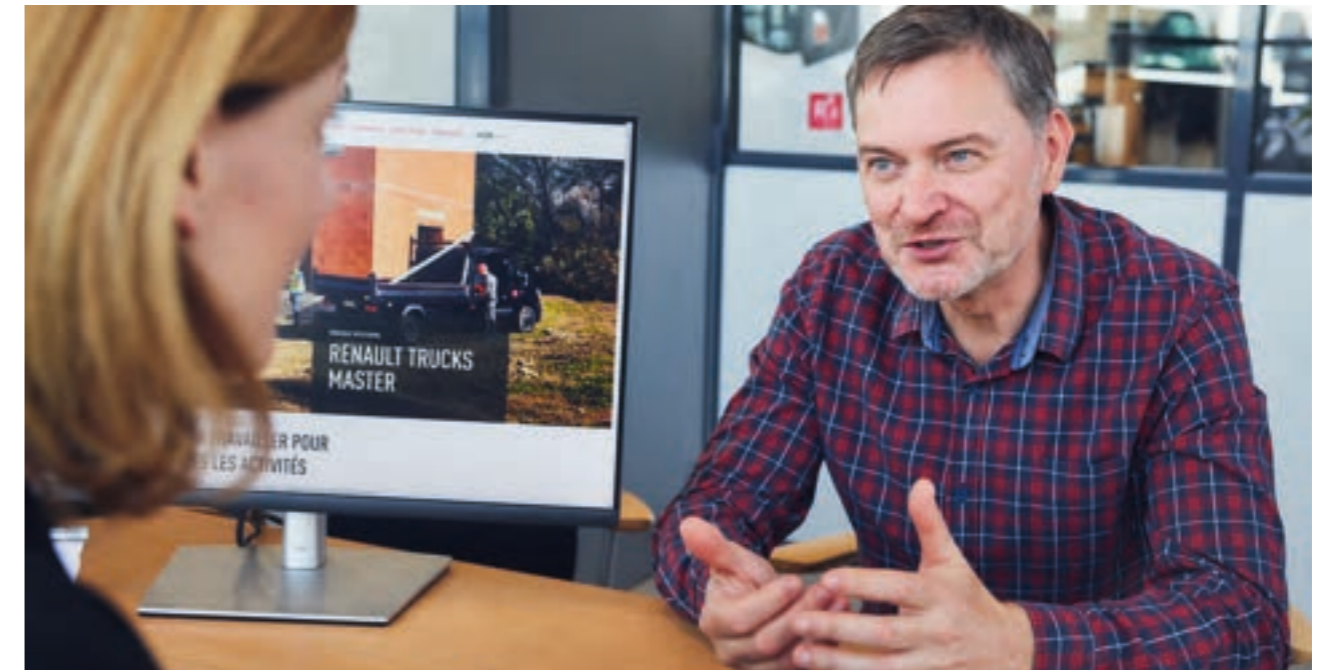

# OPTIMISE YOUR FUEL CONSUMPTION

Our latest generation 2.0 litre Euro 6 Step E engine offers optimised fuel consumption and reduced emissions output.



**150 PS ENGINE**

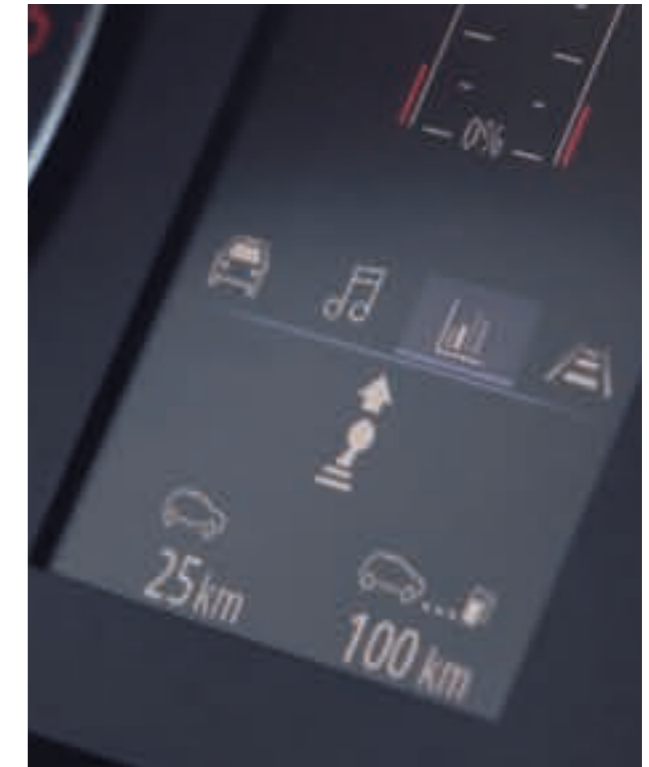

**GEARSHIFT ASSISTANCE**  
to optimise fuel consumption.



**STOP & START SYSTEM**  
standard on all engines.



**DRIVE MODE**  
standard on all models with manual transmission  
to reduce fuel consumption.



# FULLY CUSTOMISABLE

Renault Trucks can offer a vehicle configuration tailored to your business.



# CUSTOM-MADE DESIGN

You can organise the interior of your commercial vehicle to suit your business needs. Everything in its own place!

## CAREFULLY-DESIGNED INTERIOR:

- Outstanding payloads of up to 1300kgs
- Hatch under bench seat allowing up to 4.15m loads
- Bench seat with storage
- Internal ladder rack (optional)
- 1 or 2 side load doors
- Low or high roof options



# READY TO GO FOR ALL TRADES...

The Traffic Red EDITION is available in a variety of models - van, double cab, platform cab or combi to meet the needs of your business. Using special equipment (engine power take-off, additional wiring unit and body adaptation unit), Renault Trucks makes it easy to transform your vehicle.



# ... AND TO CARRY OUT ALL KINDS OF WORK



## TRACTION CAPACITY

→ Ability to tow up to 2.5 tonnes

## A COMBI MODEL FOR TRANSPORTING PASSENGERS

→ Up to 9 people and their luggage

→ Superb comfort for both driver and passengers



# SAFELY CARRY ANY TYPE OF PAYLOAD

The Renault Trucks Traffic's shape and modular structure, guarantees the best load length on the medium commercial vehicle market.

→ **MAXIMUM EFFECTIVE VOLUME**  
8.9 m<sup>3</sup>

→ **MAXIMUM EFFECTIVE HEIGHT**  
1.9 m

→ **MAXIMUM EFFECTIVE LENGTH**  
4.15 m

→ **PAYLOAD**  
up to 1300 kg



→ **AN INTERIOR DESIGNED TO TRANSPORT YOUR EQUIPMENT SAFELY**  
A latch on the left door\* and side lashing hooks to safely transport long items.

\*standard on H1 single cab models



# ...AND MAKE DELIVERIES WHERE YOUR CUSTOMERS NEED THEM

With the Renault Trucks Trafic, you can meet your customers' every need at all times, in any environment!

## HIGH-EFFICIENCY LOADING AND UNLOADING CAPABILITIES

- 180° or 270° rear doors
- Tail gate (optional)
- Twin side doors (optional)

## PRACTICAL PARKING

- Ideal for parking in urban environments due to low roof height and compact dimensions



# EVEN IN THE MOST CROWDED OR HEIGHT RESTRICTED AREAS

## REDUCED WIDTH AND HEIGHT

- Height: 1.97 m
- Width: 1.95 m

## SMALL TURNING CIRCLE

- 6.2 m



# ON BOARD COMFORT

You can even turn your cab into a functional and convenient mobile office.



Induction charger for smartphones

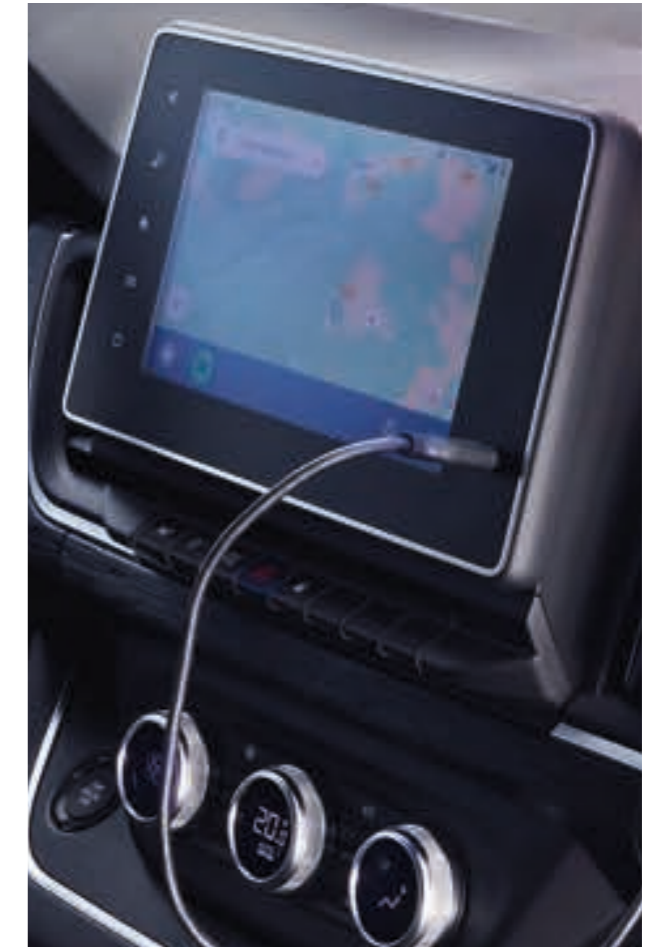

8" touch screen with smartphone mirroring



Up to 88 litres of storage space



Fold-down centre backrest provides a stable and convenient work surface



Folding bench seat



Refrigerated glove compartment



# EVERYTHING WITHIN REACH

In-cab controls are all situated within easy reach to deliver a high degree of driver usability. Driving aid systems and an automated gearbox allow the driver to concentrate on the task at hand.



1 Adaptive cruise control

2 Driver or driver and passenger airbag, optional side airbag

3 4.2" colour main display

4 Keyless starting system

5 8" touch screen with smartphone mirroring

6 Manual or regulated air conditioning

7 Induction charger for smartphones

8 Dual-clutch automated gearbox  
(on 150 and 170 hp models)

# DRIVING COMFORT

A driver's cab designed to provide a good field of vision in built-up areas.

- 1 LARGE WINDSCREEN
- 2 LED HEADLAMPS
- 3 VARIETY OF CAB TRIMS
- 4 SUN SHADE WITH BLIND SPOT WARNING



# WORK IN COMPLETE SAFETY

The Traffic Red EDITION works alongside you on each trip by using technology to enhance your safety.



Driver assistance technology and different braking systems protect people and cargo. Various items of equipment and accessories further enhance driver safety.



→ **ELECTRONIC STABILITY CONTROL - ESC**  
This safety system allows the driver to maintain directional control and prevents the vehicle from overturning in dangerous situations.



→ **FRONT AND REAR RADAR**  
Audible warning signals are emitted when an obstacle is detected.



→ **LANE DEPARTURE WARNING**  
An audible warning signal alerts the driver of unintentional drifting from the vehicle's trajectory.



→ **EXTENDED GRIP**  
Electronic management for all types of terrain (sand, snow, mud, etc.), is available as standard on both rear-wheel drive and front-wheel drive models.



→ **HILL START ASSIST**  
The brakes are held for a few seconds after releasing the pedal to make hill starts easier.



→ **CROSSWIND ASSISTANCE**  
This system helps the driver to stay in lane when experiencing crosswind.



→ **BLIND SPOT WARNING**  
The driver is warned of hazards in the blind spot using a light signal in the wing mirrors.

**ACTIVE EMERGENCY BRAKING (AEBS) AVAILABLE ACROSS THE RANGE**



→ **ADAPTIVE CRUISE CONTROL**  
to help vehicles maintain a safe following distance and automatically adjusts the speed of the vehicle below the set one.



→ **ROAD SIGN DETECTION**  
To recognise traffic signs and keeping the driver informed of speed limit changes and other important road information.

# TECHNICAL SPECIFICATIONS

## VARIOUS MODELS

→ L1H1 VAN



→ L2H1 DOUBLE CAB VAN



→ L2H1 VAN



→ L2H1 COMBI



→ L2H2 VAN



→ L2 PLATFORM CAB



## COLOURS

### SOLID LACQUER COLOURS



Glacier White



Urban Grey



Cumulus Blue



Magma Red

### METALLIC COLOURS



Highland Grey



Comet Grey



Carmin Red



Midnight Black

# FINISHES

## RED EDITION



### EXTERIOR DESIGN

Chrome radiator grille - Half-painted front bumper, body-coloured side hatch rail and light mounts



## RED EDITION EXCLUSIVE



### EXTERIOR DESIGN

Chrome radiator grille - semi-painted front bumper, body-coloured side hatch rail, light mounts, side guards, rear bumper and mirrors, Red EDITION stickers



### UPHOLSTERY

Carbon grey fabric



### WHEEL RIMS

Metal 16" - standard hub casing



### UPHOLSTERY

Black geometric fabric

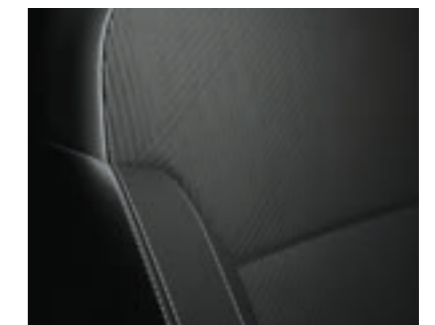

### WHEEL RIMS

Aluminium 17"

● Silver ● Black ● Red



# ACCESSORIES



Towing hook



Roof rack solutions



Door sill concealing panel



Red EDITION mat



Foot board



Red EDITION covers



Side hatch lock



EWP cargo lining to floor and sides

# RANGE OVERVIEW

	Van		Double cab van	Platform cab	9-seater Combi
	L1H1 L2H1	L1H2 L2H2	L1H1 L2H1	L2	L1H1 L2H1
<b>Equipment level</b>	Red EDITION Red EDITION EXCLUSIVE		Red EDITION	Red EDITION	Red EDITION
<b>Manual gearbox engine</b>	110 hp 130 hp 150 hp 170 hp		110 hp 130 hp 150 hp 170 hp	150 hp 170 hp	150 hp
<b>Automated dual clutch engines</b>	150 hp 170 hp		150 hp 170 hp	-	150 hp 170 hp
<b>GCW</b>	L1H1: 3T L2H1: 3T1		3T	3T	2T8

# POWER TRAIN

	110 hp Stop & Start	130 hp Stop & Start	150 hp Stop & Start	170 hp Stop & Start
<b>Engine capacity</b>	4 cylinders / 2.0 L / Single Turbo			
<b>Maximum power at 3500 rpm</b>	81 kW	96 kW	110 kW	125 kW
<b>Maximum torque at 1500 rpm</b>	300 Nm	320 Nm	350 Nm	380 Nm
<b>Type of injection</b>	Common Rail Direct Injection (2500 bar)			
<b>Tank Capacity (Fuel / AdBlue)</b>	80 L / 24.7 L			
<b>Transmission</b>	Manual 6-speed		Manual 6-speed / EDC6 dual clutch	
<b>Standard</b>	EURO 6 D-FULL			
<b>Cycle</b>	WLTP (Worldwide harmonized Light vehicles Test Procedures)			
<b>Fuels compliant with European standards with which the engines of vehicles sold in Europe are compatible</b>	<b>B7</b> : EN590 compliant fuel containing up to 7% fatty acid methyl esters by volume <b>B10</b> : EN16734 compliant fuel containing up to 10% fatty acid methyl esters by volume <b>XTL</b> : EN15940 compliant paraffinic diesel fuel containing up to 7% fatty acid methyl esters by volume			

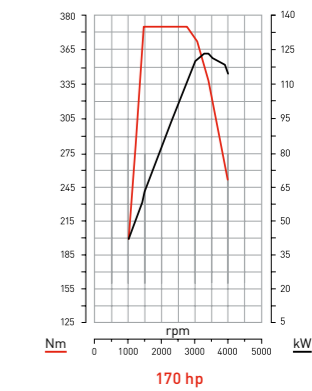
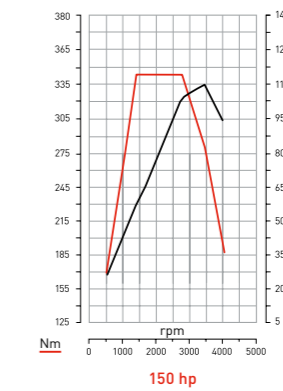
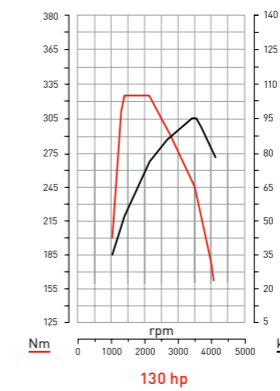
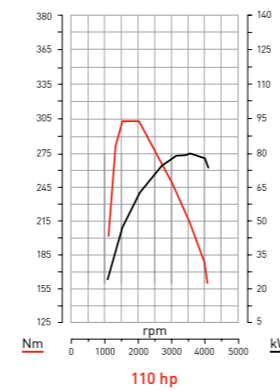

# WEIGHTS AND DIMENSIONS

## VAN / DOUBLE CAB VAN

FRONT-WHEEL DRIVE	Van				Double cab van	
	L1H1	L1H2	L2H1	L2H2	L1H1	L2H1
GCW	3 t	3 t	3.1 t	3 t	3 t	3 t
<b>External dimensions</b>						
Overall length	5080 mm		5480 mm		5080 mm	5480 mm
Long overhang	1014 mm					
Wheelbase	3098 mm		3498 mm		3098 mm	3498 mm
Rear overhang	968 mm					
Overall width / with wing mirrors	1956 / 2283 mm					
Total height	1971 mm	2495 mm	1967 mm	2498 mm	1971 mm	1967 mm
Turning circle, kerb-to-kerb / wall-to-wall	6.2 / 6.4 m		6.9 / 7.18 m		6.2 / 6.4 m	6.9 / 7.18 m
Min. ground clearance	160 mm					
<b>Weight and loads</b>						
Net Payload (Inc. driver at 75 kg and 90% full fuel)	976 kg	902 kg	1,144 kg	865 kg	TBA	TBA
Max. load on front axle	1625 kg					
Max. load on rear axle	1650 kg					
Maximum towable mass (unbraked / braked) manual gearbox	750 / 2500 kg					
Maximum towable mass (unbraked / braked) EDC	750 / 1800 kg	-	750 / 1690 kg	-	750 / 1800 kg	750 / 1690 kg
<b>Loading area (mm)</b>						
Effective volume	5.8 m <sup>3</sup>	6.7 m <sup>3</sup>	7.75 m <sup>3</sup>	8.9 m <sup>3</sup>	3.36 m <sup>3</sup>	4.3 m <sup>3</sup>
Width x length of bulkhead hatch	510 X 222 mm				-	
Internal effective length / to 1m	2537 mm		2937 mm		2023 / 1340 mm	2423 / 1740 mm
Internal effective floor length including under-seat area / footwell	2950 / 3750 mm		3350 / 4150 mm		-	
Effective height	1387 mm	1898 mm	1387 mm	1898 mm	1387 mm	
Internal effective width	1662 mm					
Width between wheel arches	1268 mm					
<b>Sliding side hatch(es)</b>						
Height	1284 mm					
Width to 100 mm / 600 mm	1030 / 907 mm					
<b>Rear doors</b>						
Height	1320 mm	1820 mm	1320 mm	1820 mm	1320 mm	1820 mm
Width (to 70 mm)	1391 mm					
Loading sill	552 mm					

# CABS

## VAN

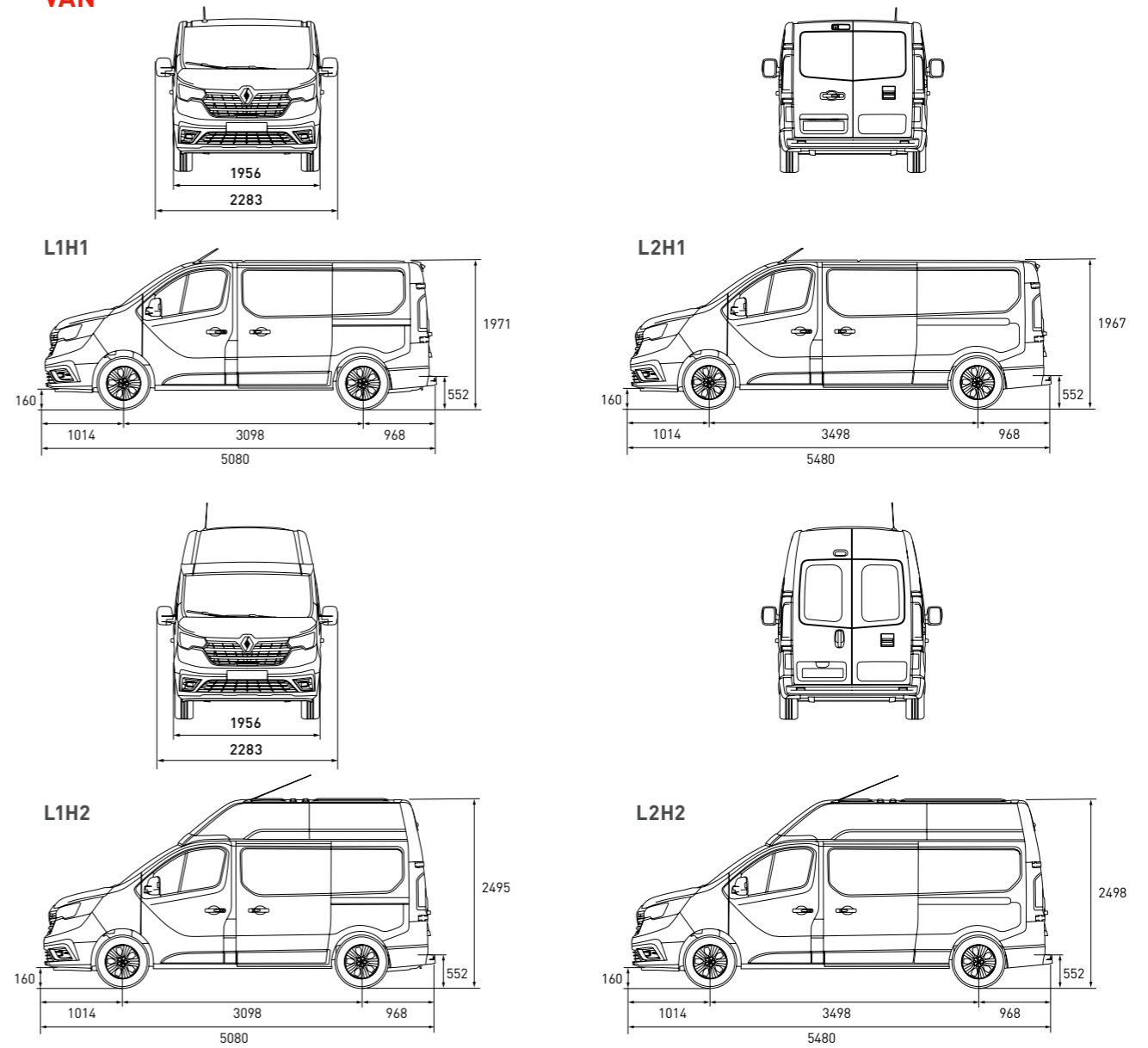

## DOUBLE CAB VAN

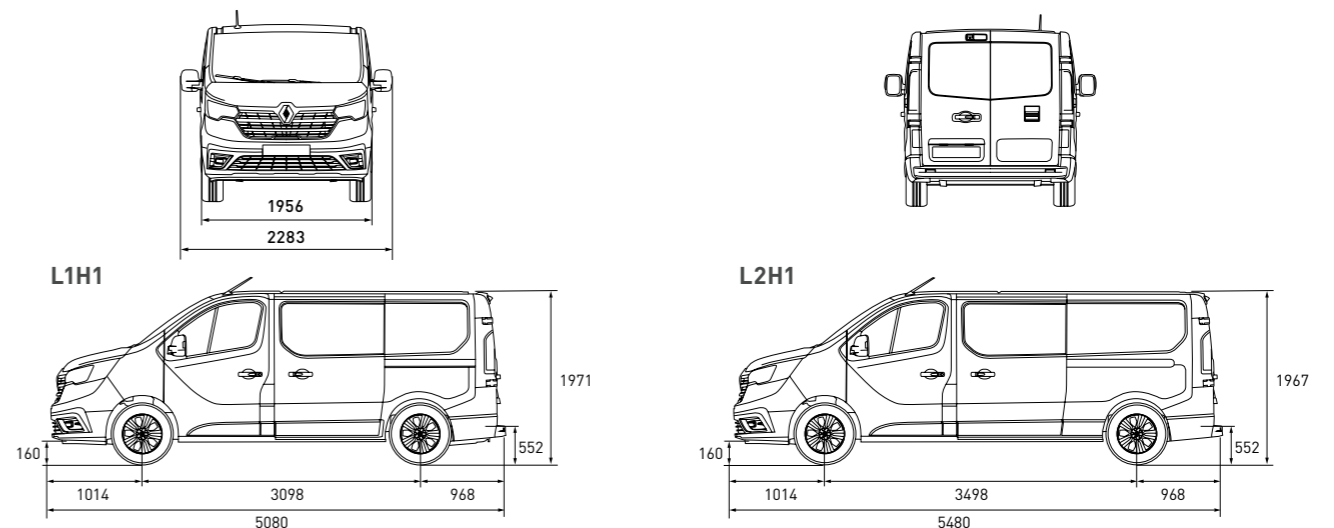

# WEIGHTS AND DIMENSIONS

## PLATFORM CAB / 9-SEATER COMBI

	Platform Cab	9-seater Combi	
<b>FRONT-WHEEL DRIVE</b>	L2	L1H1	L2H1
GCW	3 t	3 t	3 t
<b>External dimensions</b>			
Overall length	5248 mm	5080 mm	5480 mm
Long overhang	1014 mm		
Wheelbase	3498 mm	3098 mm	3498 mm
Rear overhang	817 mm	968 mm	
Overall width / with wing mirrors	1956 / 2283 mm	1956 / 2283 mm	
Total height	1967 mm	1971 mm	1967 mm
Turning circle, kerb-to-kerb / wall-to-wall	6.9 m / depending on body	6.2 / 6.4 m	6.9 / 7.18 m
Min. ground clearance	160 mm	160 mm	
<b>Weight and loads</b>			
Max. load on front axle	1585 kg	1625 kg	
Max. load on rear axle	1650 kg	1650 kg	
Maximum towable mass (unbraked / braked) manual gearbox	750 / 2000 kg	750 / 2500 kg	
Maximum towable mass (unbraked / braked) EDC	-	750 / 1800 kg	750 / 1690 kg
<b>Effective volume</b>			
8-9 seater model	-	1 m <sup>3</sup>	1.8 m <sup>3</sup>
3rd row folded down / removed	-	2.5 / 3.2 m <sup>3</sup>	3.4 / 4.1 m <sup>3</sup>
2nd row folded down / removed	-	4.7 / 5.2 m <sup>3</sup>	5.7 / 6.0 m <sup>3</sup>
<b>Internal dimensions</b>			
Loading length in 8-9 seater version	-	736 mm	1136 mm
Loading length 3rd row folded down / removed	-	1152 / 1650 mm	1552 / 2050 mm
Loading length 2nd row folded down / removed	-	2066 / 2537 mm	2466 / 2937 mm
Effective height	-	1369 mm	
Maximum internal width	-	1662 mm	
Width between wheel arches	-	1268 mm	
<b>Sliding side hatch(es)</b>			
Height	-	1284 mm	
Width to 100 mm / 600 mm	-	1030 / 907 mm	
<b>Rear opening (mm)</b>			
Door height 180° / tailgate	-	1320 / 1295 mm	
Width (to 70 mm)	-	1391 mm	
Loading sill	-	552 mm	

# CABS

## PLATFORM CAB

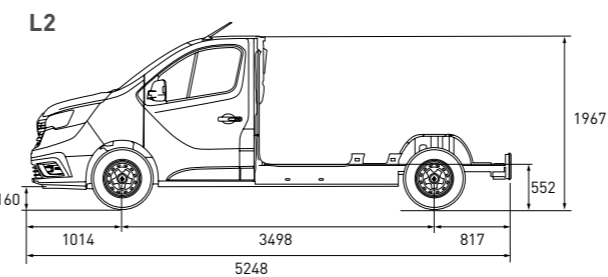
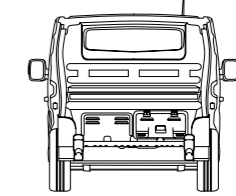
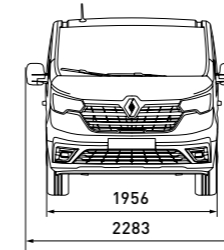

## 9-SEATER COMBI

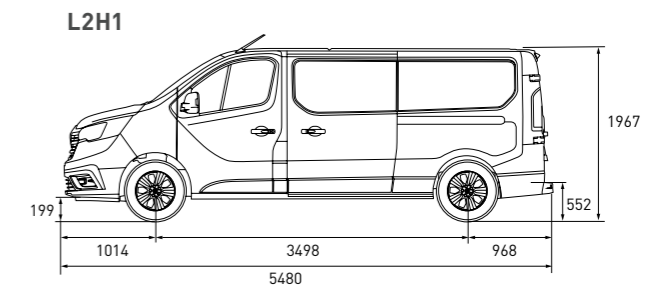
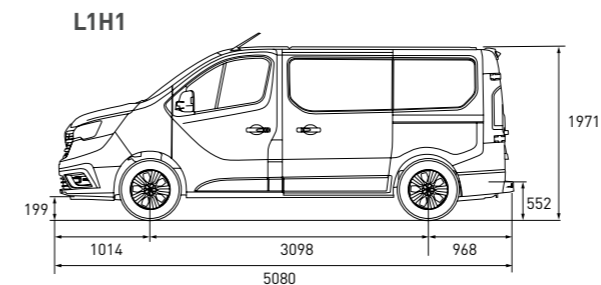
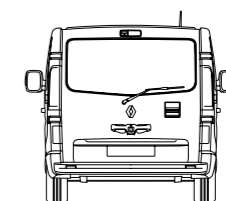
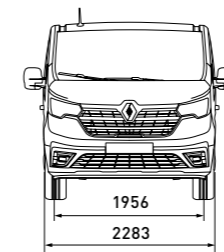





We recommend Renault Trucks Oils.  
Dimensions and specifications are provided for guidance only.  
The manufacturer reserves the right to change them without prior notice.



[renewal-trucks.co.uk](https://renewal-trucks.co.uk)



08/2022